

# AllSpark

**POWERING YOU OFFROAD**

**DUAL OUTLET SWITCHED POWER BOARD**



# GENERAL SAFETY WARNING

This device has electrical outputs identical to electrical outlets in your home. There is a risk of electrocution or death if not used correctly or if damaged. If the supply cord is damaged, it shall be replaced by the manufacturer or its service agent or similarly qualified person to avoid an electrical hazard which could cause serious injury or death if not correctly rectified. If the power board requires repair, contact Offroad Living Australia Customer Service on +61 8 6205 6868. Never disassemble or modify the power board or attempt to service it yourself.

Run the supply cord such that there is no risk of anyone pulling it inadvertently or tripping over it. If there is potential for impact or rubbing of the cable from vehicle contents or otherwise, protect the supply cord with appropriate conduit or ducting.

The power board is not intended for use by people (including children) with reduced physical, sensory or mental capabilities, or lack of experience and knowledge unless they are under supervision or instruction by a competent person responsible for their safety. Young children should be supervised to ensure they do not play with this device. Supervision is necessary when any appliance is used by or near children.

This device is designed for indoor or in vehicle use only – DO NOT expose to moisture or dust. The total load connected must not exceed the current rating of 10A AC. If the supply cord is damaged, remove it from service & contact the seller for spare parts.

Do not exceed a maximum load of 2400 watts or 10A AC.

Before installing the power board, make sure to place it away from heat sources, long periods of direct sunlight, radiators, areas with high ambient temperatures or other devices/appliances that produce excess heat. Avoid exposure to high humidity or excess dirt and dust, open windows and any place where water may get to the unit.

Do not immerse the cord, plug or power board in water or any other liquid.

# INFORMATION

## Current Overload Protection

The power board features overload protection to prevent damage to your electrical equipment. If the total power draw exceeds the rated capacity shown below, the socket will automatically turn off, ensuring safety and protecting appliances. Enjoy peace of mind knowing your appliances are always protected from excess current damage.

**SPECIAL NOTE: The over-current protection is not a Residual Current Device.**

## Technical Parameters

|  |   |
|--|---|
| <b>Model:</b>                              | AS-DUALPP   |
| <b>Power:</b>                              | 10A Max/2400W Max   |
| <b>Voltage:</b>                            | 230-240V @ 50Hz   |
| <b>Over Current Protection:</b>            | 10A push button resettable circuit breaker  |
| <b>Input socket:</b>                       | IEC 14 10A socket on body   |
| <b>Power Cord plug type:</b>               | IEC 13 10A right angle cord   |
| <b>Cord length:</b>                        | 2m  |
| <b>Dimensions:</b>                         | Front plate - 100mm x 100mm<br>Securing ring – 115mm diameter<br>Depth of body – 56mm |
| <b>Mounting:</b>                           | Hole Cutout size 89-90mm  |
| <b>Minimum Clearance required:</b>         | 116mm rear width to install collar  |
| <b>Mounting surface thickness options*</b> | 1-30mm  |
| <b>Material:</b>                           | Flame Retardant PC  |

\* Mounting note: If the mounting surface material thickness is less than 1mm, a spacer material or gasket may be required to close the gap.

# Drawings

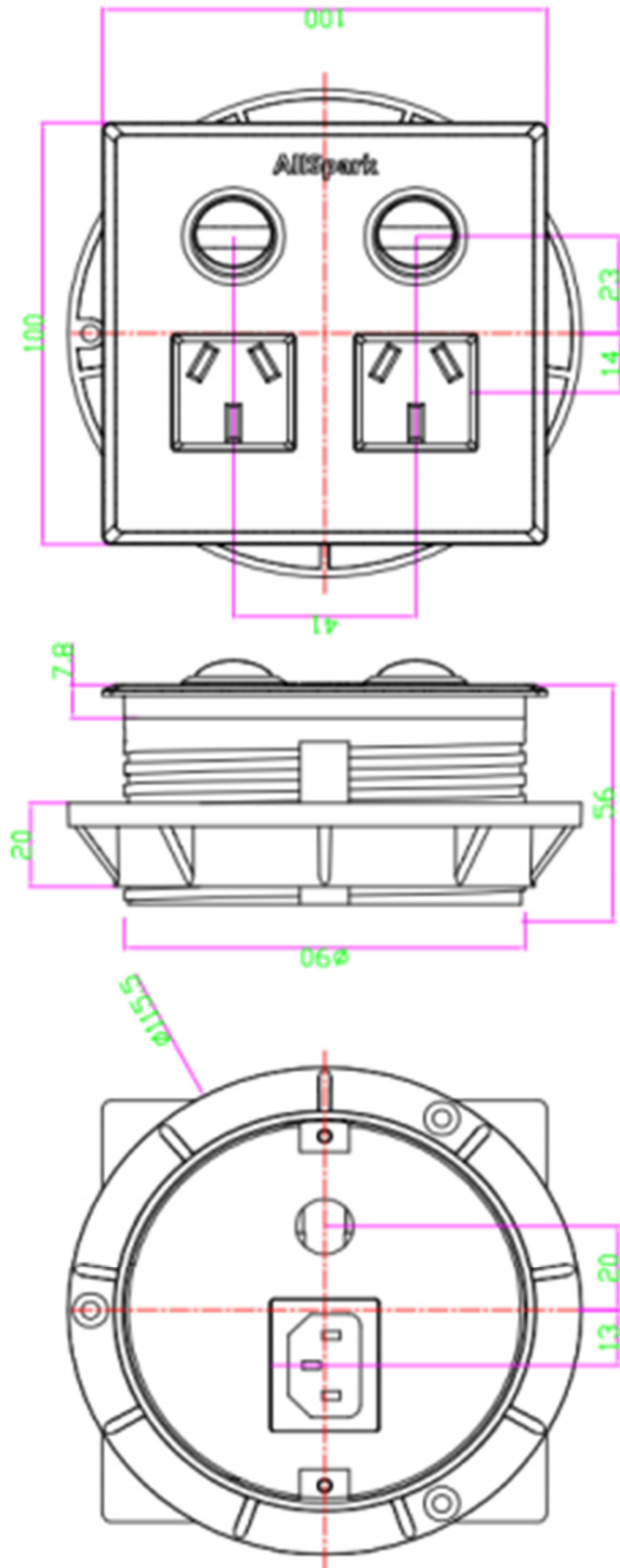

## **Cleaning**

Only use soft, dry cloth for cleaning the product. Do not use a damp cloth at any time. Never clean with detergent or chemicals. Wipe off any moisture, dirt or dust on the power sockets with a clean, dry cloth.

## **Storage**

When not in use, disconnect from the power source or isolate the source and store it in a cool, dry and well-ventilated location out of direct sunlight, and not subject to humidity or moisture.

## **Warranty**

In addition to any rights you have at law, we provide you with the following limited warranties:

1. 30-day limited warranty to repair or replace the Goods (at our option) subject to the following conditions:
  - a. the warranty will only apply if we receive notice of a claim by you during the period commencing on the day you receive delivery of the Goods (and such delivery will be deemed to have occurred on the earlier of any recorded delivery by any third-party delivery service or the expected delivery period identified on our Website or in store) and ending 30 days later; and
  - b. where the Goods are found to be defective and you notify us within the above period, we will cover the shipping costs of the Goods to our nominated address and for the replacement or repaired Goods to be delivered to you.
2. An extended warranty to repair or replace the Goods (at our option) subject to the following conditions:
  - a. the warranty will only apply if we receive a notice of a claim by you during the period commencing on the date that is 30 days after the date of delivery of the Goods to you (and such delivery will be deemed to have occurred on the earlier of any recorded delivery by any third party delivery service or the expected delivery period identified on our Website or Store) and ending on the date that is 12 months later; and

- b. you will be solely responsible for the delivery of the Goods to and from our nominated address.
3. Both warranties specified in clause 1 are subject to the following terms and conditions:
  - a. the warranty covers defects in materials and workmanship only;
  - b. you may only claim under this warranty if all parts of the Goods are maintained in accordance with any recommendations, which we have conveyed to you, including via any instruction manuals maintained on our Website or supplied by the manufacturer;
  - c. you may only claim on this warranty if you have complied with all the terms of the Agreement and any other reasonable requirements we request;
  - d. you may not claim this warranty to the extent that any costs, loss or damage to the Goods arises as a result of or in connection with fair wear and tear of the Goods or your own negligence or act or omission.
4. If, during either period specified in clause 1 you notify us that Goods you have received are defective, then we will, at our option, either repair or replace the Goods at our cost.
5. No Goods will be accepted for return, repair or replacement under either warranty without our prior written consent.

Warranty claims must be made in writing to the original seller providing the fault or defect, photos of the issue and original proof of purchase. For purchases direct from Offroad Living, this can be submitted via [warranty@offroadliving.com.au](mailto:warranty@offroadliving.com.au) or via [www.offroadliving.com.au](http://www.offroadliving.com.au)

## **Consumer Guarantees**

1. Our Goods come with guarantees that cannot be excluded under the Australian Consumer Law. These guarantees are not limited by a defined timeframe.
2. If any Goods you purchase have a major failure, you may reject them and seek a refund, exchange or repair and compensation for any other reasonably foreseeable loss or damage or you may keep the Goods and seek compensation for any drop in value.
3. You are also entitled to have the Goods repaired or replaced if they fails to be of acceptable quality and the failure does not amount to a major failure. If the failure is not a major failure, we may at our discretion repair or replace the Goods or refund the price of the Goods to you within a reasonable time.
4. The Australian Consumer Law recognises that the relevant time period may vary by depending on the nature of the goods, the price paid, and any representations made about the goods.
5. Where you believe any Goods are faulty or defective, it may be necessary for us to send your Goods to the manufacturer or their service agent for them to be assessed within a reasonable period.
6. Where any Goods are damaged through misuse, neglect or abnormal use, you will not be entitled to a refund, exchange or repair.
7. We require satisfactory proof of purchase of the of the relevant Goods before providing a remedy under the Australian Consumer Law.

## **Contact Information**

### **Technical support:**

You can contact Offroad Living customer service via the following methods

Phone: +61 8 6205 6868

Email: [contact@offroadliving.com.au](mailto:contact@offroadliving.com.au)

Website: [www.offroadliving.com.au](http://www.offroadliving.com.au)

Facebook: [www.facebook.com/offroadliving](http://www.facebook.com/offroadliving)

## **Legal & Compliance**

This product has been designed and manufactured by Offroad Living in Australia. This product has a “Patent Pending” Status with IP Australia. It must not be copied in any form. It has been tested and certified to be compliant with all relevant Australian/New Zealand Electrical standards in accordance with AS 3105 Testing Standard – Type Testing.

Compliance standards:

- AS/NZS 3000:2018
- AS/NZS 3001:2022
- AS/NZS 3100:2022
- AS/NZS 3105:2014+A1: 2017
- AS/NZS 3111
- AS/NZS 3112:2017+A1:2021
- AS/NZS 3120
- AS/NZS 3121
- AS/NZS 3133:2020
- AS/NZS 3191/AS/NZS 60227.4 & 5
- AS/NZS 60320.1

Electrical Safety Certifications

- SAA No: SAA-241106-EA
- RCM Compliance RCM240927927

AllSpark is a registered Trademark of Offroad Living, registered in Australia.



